

R2646

ELECTRIC SCISSOR LIFT

SCISSOR LIFT



KEY SPECS

Platform Height
26-ft / 7.92-m

Platform Capacity
1,200-lb / 545-kg

Number of Occupants
Indoor: 2
Outdoor: 1

Stowed Drive Speed
3 mph / 4.8 km/h

KEY FEATURES

- The 1,200-lb indoor and outdoor platform capacity beats the competition.
- Active pothole protection provides increased ground clearance to tackle demanding terrain.
- Built rugged for rentals, allows professionals to meet the demands of any job site.
- Complies with A92.20 ANSI regulations, achieving the highest standards.

ACCESSORIES & OPTIONS

- 4 x 6V AGM Batteries, 220 ah
- 4 x 6V Batteries, 255 ah
- 900W Inverter
- Anti-Vandalism PKG
- Ambient Noise Alarm
- Coiled Platform Control Box Cable
- Drive Motor Covers
- Eagle Performance Charger
- Extension Deployment Handles
- Fire Extinguisher
- Flashing Amber Beacon
- JLG® Mobile Control
- MDI (Ground)
- Pipe Racks
- SkySense® Enhanced Detection System

STANDARD SPECIFICATIONS

Performance	Indoor	Outdoor
Platform Height (Elevated)	26-ft / 7.92-m	26-ft / 7.92-m
Platform Capacity	1,200-lb / 545-kg	1,200-lb / 545-kg
Capacity on Platform Extension	265-lb / 120-kg	
Number of Occupants	2	1
Lift / Lower Time (No Load)	47/44 seconds	47/44 seconds
Lift / Lower Time (Rated Load)	54/37 seconds	54/37 seconds
Maximum Drive Height	Fully Elevated	Fully Elevated
Weight*	5,267-lb / 2,389-kg	5,267-lb / 2,389-kg
Max. Ground Bearing Pressure	122 psi / 8.6 kg/cm ²	122 psi / 8.6 kg/cm ²
Drive Speed (Lowered)	3 mph / 4.8 km/h	3 mph / 4.8 km/h
Drive Speed (Raised)	0.5 mph / 0.8 km/h	0.5 mph / 0.8 km/h
Gradeability	25%	25%
Max Tilt Rating - Side-to-Side (Indoor)	2.5 Degrees	1.5 Degrees
Max Tilt Rating (Fore and Aft)	3.5 Degrees	3.5 Degrees
Turning Radius (Inside)	Zero	Zero
Turning Radius (Outside)	88-in / 2.24-m	88-in / 2.24-m

*Certain options or country standards increase weight

Power Source

Battery	4 x 6V 220 amp-hr
Charger	27 amp
Drive	Hydraulic Front-Wheel

Tires

Standard	16 x 5-in / 406 x 127-mm
----------	--------------------------

Brakes

Multi-Disc Friction

Hydraulic System

Capacity	4 gal / 15 L
Pump	Fixed Displacement Gear

STANDARD FEATURES

- 27 amp Multi-Function Universal Charger
- AC Receptacle in Platform
- Active Pothole Protection System
- All Motion Alarm
- Analyzer Port for Diagnostics
- Battery Condition Indicator
- Diamond Tread Steel Deck
- Dynamic Braking
- Fork Lift Pockets
- Foot-Actuated Deck Extension
- Greaseless Kingpin Joints
- Horn
- Hourmeter
- Lanyard Attach Points
- Lifting and Tie Down Points
- Lubrication Free Scissor Arm Bushings
- Manual Descent Cable
- Movable, Removable Platform Control
- Nickel Plated Pins
- Proportional Controls
- Removable Ladder
- Scissor Maintenance Prop
- Steel Swing-Out Doors
- Tilt Alarm and Light
- Variable Tilt Visual Zone Indicator

R2646

ELECTRIC SCISSOR LIFT

SCISSOR LIFT



DIMENSIONS

All dimensions are approximate

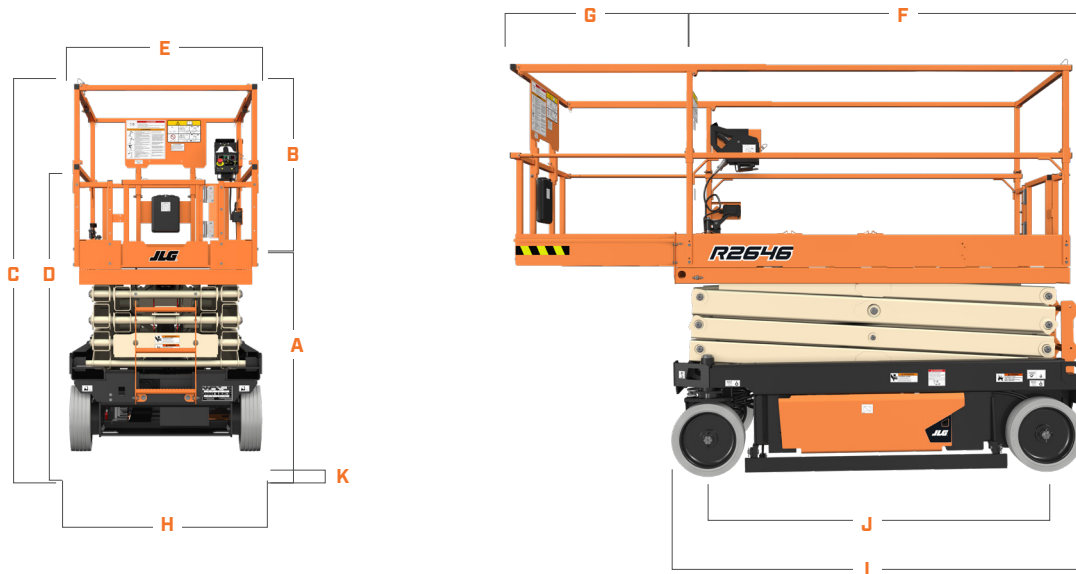

A. Platform Height (Lowered)	45-in / 1.14-m
B. Platform Railing Height	44.6-in / 1.1-m
C. Machine Height (Rails Raised)	89.6-in / 2.28-m
D. Machine Height (Rails Lowered)	71.7-in / 1.82-m
E. Platform Width	41.6-in / 1.1-m
F. Platform Length	84-in / 2.1-m

G. Platform Extension	36-in / 91-cm
H. Machine Width	46-in / 117-cm
I. Machine Length	94.3-in / 2.4-m
J. Wheelbase	74-in / 1.9-m
K. Ground Clearance	3.9-in / 9.8-cm



We provide coverage for one (1) full year, and cover all specified major structural components for five (5) years. Due to continuous product improvements, we reserve the right to make specification and/or equipment changes without prior notification. This machine meets or exceeds applicable ANSI and CSA requirements based on machine configuration as originally manufactured for intended applications. Please reference the serial number plate on the machine for additional information.



JLG INDUSTRIES, INC.
Toll-free US 877-JLG-LIFT
JLG.com

An Oshkosh Corporation Company