

Climax P154-I0N: Electric pallet truck

- Reliable and more durable drive system
- New plug in & out maintenance-free lithium battery with integrated charger
- ca. 2h charging time for 100%
- Stable operation thanks to industrial universal floating wheels
- Creep speed function

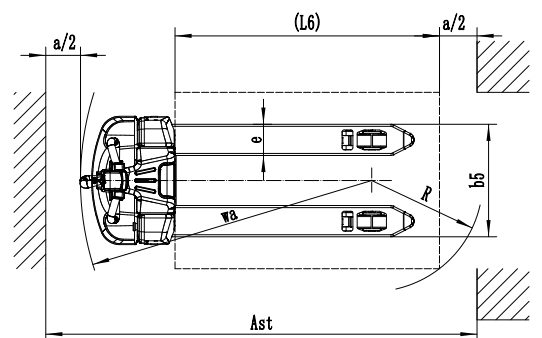

Characteristics			
1.2	Model designation		P154-I0N
1.3	Drive unit		Battery
1.4	Operator type		Pedestrian
1.5	Load capacity	Q (kg)	1500
1.6	Load center distance	c (mm)	600
1.8	Load distance, centre of drive axle to fork	x (mm)	940
1.9	Wheelbase	y (mm)	1200
Weights			
2.1	Service weight (Incl. battery)	kg	150
2.2	Axle loading, loaden operator/load side	kg	510/1140
2.3	Axle loading, unloaden operator/load side	kg	120/30
Wheels, Chassis			
3.1	Tyre type		PU/PU
3.2	Tyre size, operator side	mm	Ø 210 x 70
3.3	Tyre size, load side	mm	Ø 80 x 60
3.4	Balance wheels (dimensions)	mm	Ø 74 x 30
3.5	Wheels, number operator/load side (x = drive wheels)		1 x 2/4
3.6	Tread, operator side	b10 (mm)	450
3.7	Tread, load side	b11 (mm)	390
Dimensions			
4.4	Lift height	h3 (mm)	115
4.9	Height of tiller arm in operating position, min/max	h14 (mm)	700/1260
4.15	Fork height, lowered	h13 (mm)	80
4.19	Overall length	l1 (mm)	1550
4.20	Length to face of forks	l2 (mm)	400
4.21	Overall width	b1 (mm)	610
4.22	Fork dimensions	s/e/l (mm)	50 x 150 x 1150
4.25	Width across forks	b5 (mm)	540
4.32	Ground clearance, center of wheelbase	m2 (mm)	30
4.33	Aisle width, 1000 x 1200 pallet crossways	Ast (mm)	2145
4.34	Aisle width, 800 x 1200 pallet lengthways	Ast (mm)	2050
4.35	Turning radius	Wa (mm)	1330
Performance			
5.1	Travel speed, loaden/unloaden	km/h	4,5/5
5.2	Lift speed, loaden/unloaden	m/s	0,028/0,031
5.3	Lowering speed, loaden/unloaden	m/s	0,068/0,043
5.8	Maximum gradeability, loaden/unloaden	%	6/16
5.10	Service brake		Electromagnetic
Drive			
6.1	Drive motor performance S2 60 min	kW	0,75
6.2	Lift motor performance at 15%	kW	0,8
6.3	Battery type		Li-on
6.4	Battery voltage/nominal capacity	V/Ah	24/30
6.5	Battery weight	kg	10
6.6	Power consumption according to VDI cycle	kWh/h	0,25
	Charger incorporated	V/A	24/10
Others			
8.1	Type of drive control		DC
10.5	Steering Type		Mechanical
10.7	Sound level at operator's ear dB (A)	dB (A)	<74

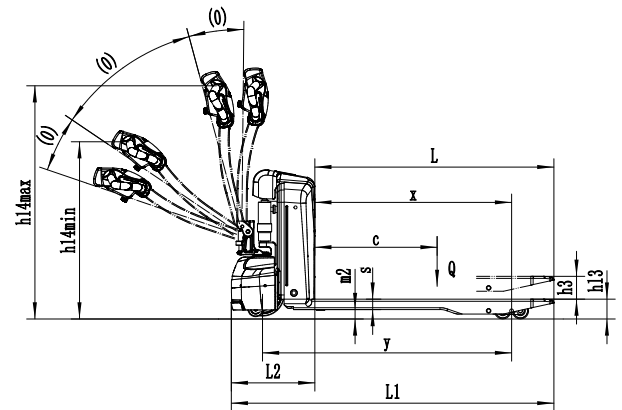

TVH* and Climax® are registered trademarks. © 04-2021, TVH Equipment NV, Brabantstraat 15, B-8790 Waregem. All rights reserved. No part of this publication may be reproduced or communicated in any form or by any means, electronic or mechanical, including copying, recording or use in an information storage or retrieval system, without prior and explicit permission of TVH Equipment NV.

E0BRSS_2101002

Climax®

info@climaxhandling.com · www.climaxhandling.com
TVH Equipment NV · Brabantstraat 15 · 8790 Waregem · Belgium